

RIZVI COLLEGE OF ARTS, SCIENCE & COMMERCE

PIN DIAGRAM OF 8085

FOR XII COMPUTER SCIENCE

PAPER II CHAPTER 1

ZAMEER HASAN SHAIKH

Department of Computer Science

Introduction to 8085

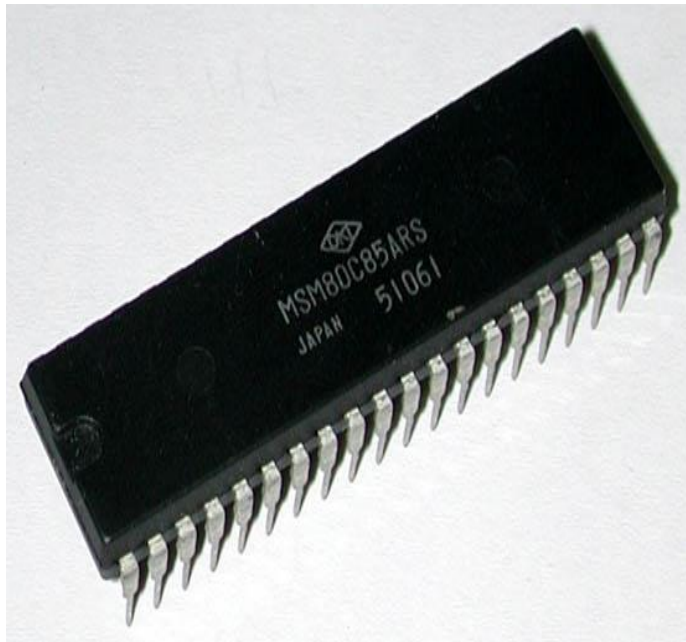

- It was introduced in 1977.
- It is 8-bit microprocessor.
- Its actual name is 8085 A.
- It is single NMOS device.
- It contains 6200 transistors approx.
- Its dimensions are 164 mm x 222 mm.
- It is having 40 pins Dual-Inline-Package (DIP).

Pin Diagram of 8085

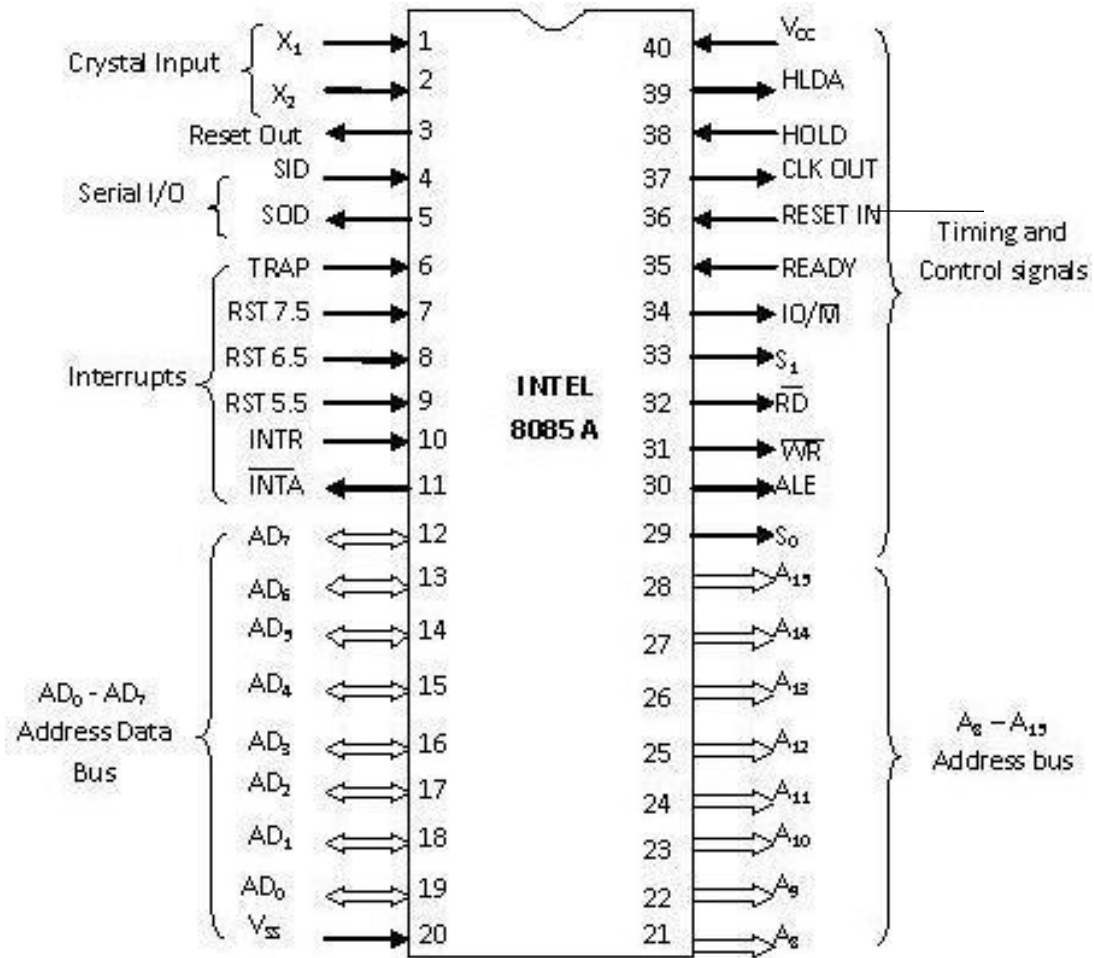

X_1 & X_2

Pin 1 and Pin 2 (Input)

- These are also called Crystal Input Pins.
- 8085 can generate clock signals internally.
- To generate clock signals internally, 8085 requires external inputs from X_1 and X_2 .

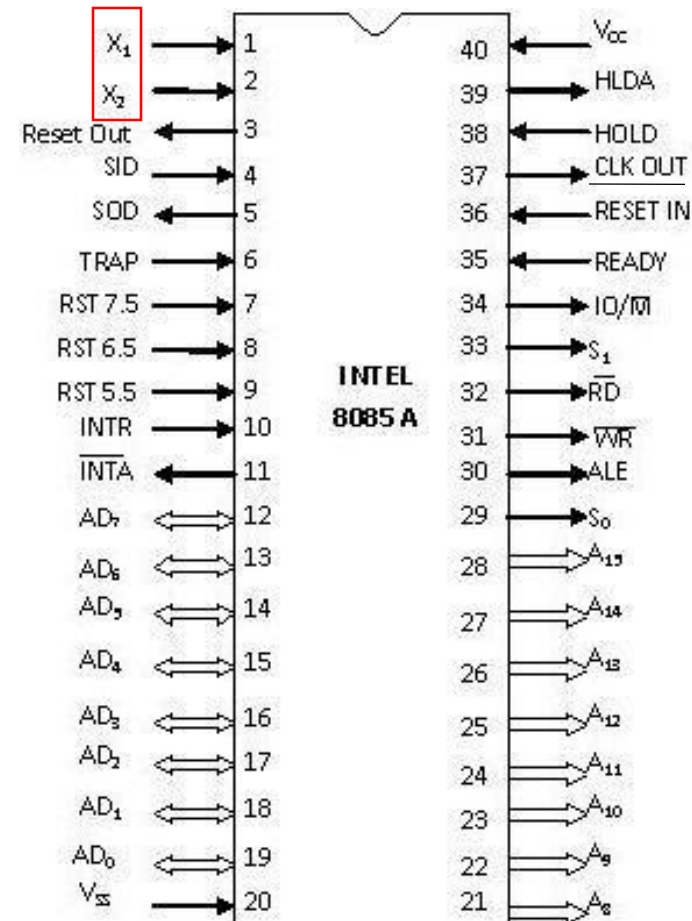

RESET IN and RESET OUT

Pin 36 (Input) and Pin 3 (Output)

- **RESET IN:**

- It is used to reset the microprocessor.
- It is active low signal.
- When the signal on this pin is low for at least 3 clocking cycles, it forces the microprocessor to reset itself.

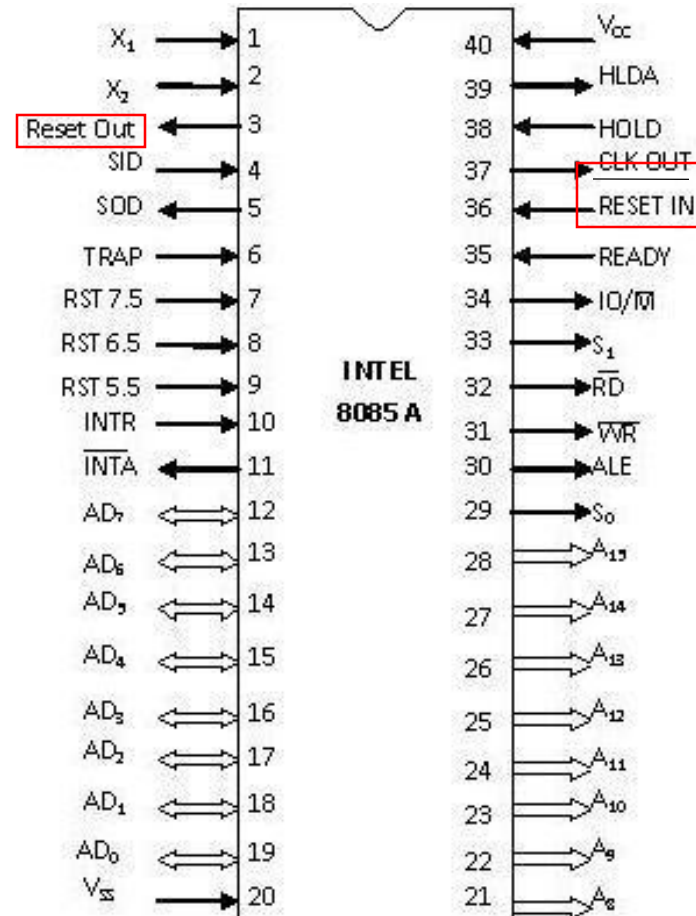

RESET IN and RESET OUT

Pin 36 (Input) and Pin 3 (Output)

- Resetting the microprocessor means:
 - Clearing the PC and IR.
 - Disabling all interrupts (except TRAP).
 - Disabling the SOD pin.
 - All the buses (data, address, control) are **tri-stated**.
 - Gives HIGH output to RESET OUT pin.

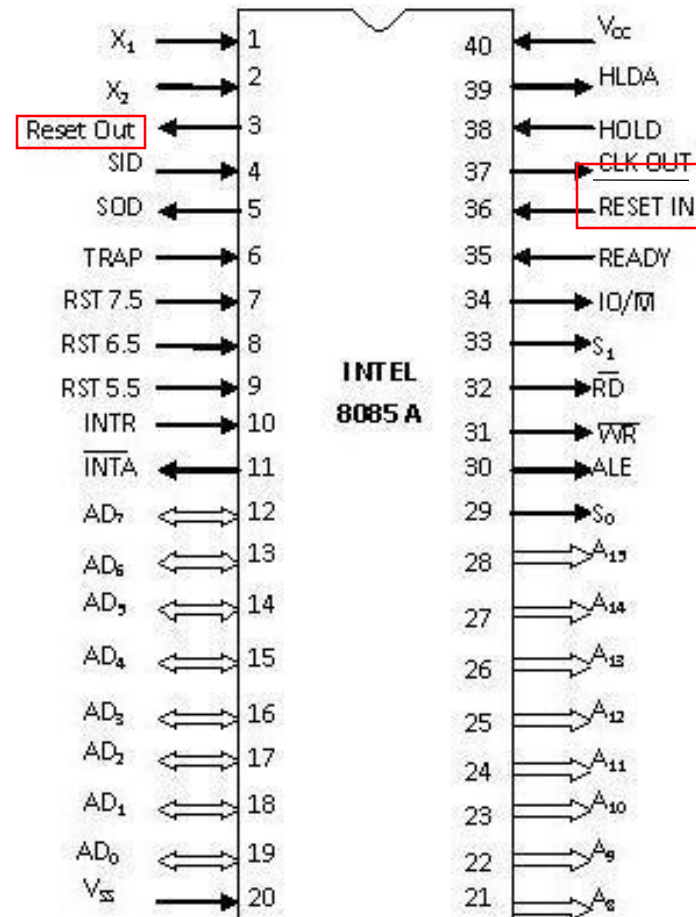

RESET IN and RESET OUT

Pin 36 (Input) and Pin 3 (Output)

- **RESET OUT:**

- It is used to reset the peripheral devices and other ICs on the circuit.
- It is an output signal.
- It is an active high signal.
- The output on this pin goes high whenever RESET IN is given low signal.
- The output remains high as long as RESET IN is kept low.

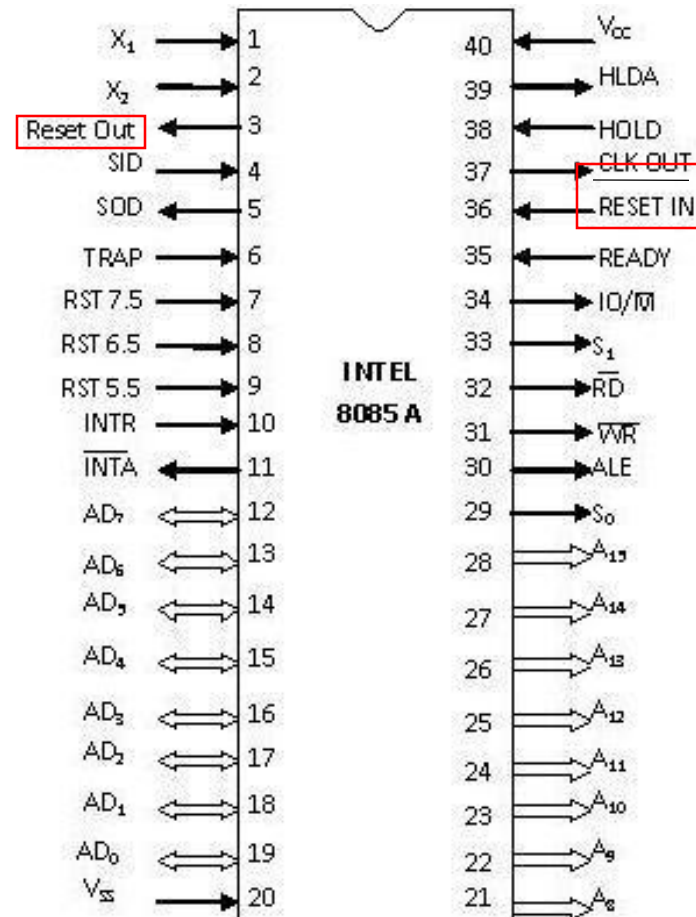

SID and SOD

Pin 4 (Input) and Pin 5 (Output)

- **SID (Serial Input Data):**

- It takes 1 bit input from serial port of 8085.
- Stores the bit at the 8th position (MSB) of the Accumulator.
- RIM (Read Interrupt Mask) instruction is used to transfer the bit.

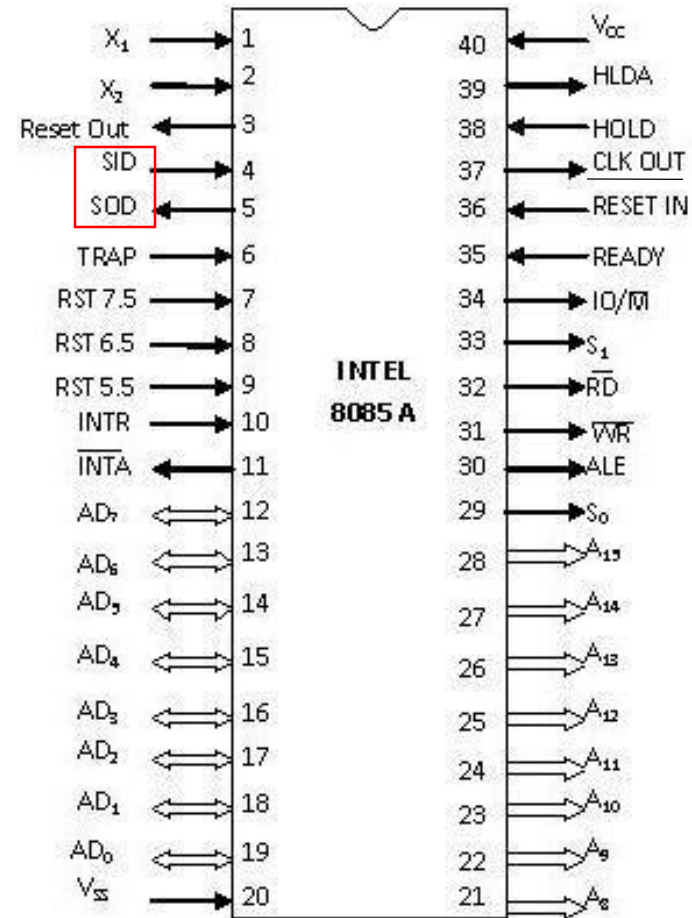

SID and SOD

Pin 4 (Input) and Pin 5 (Output)

- **SOD (Serial Output Data):**

- It takes 1 bit from Accumulator to serial port of 8085.
- Takes the bit from the 8th position (MSB) of the Accumulator.
- SIM (Set Interrupt Mask) instruction is used to transfer the bit.

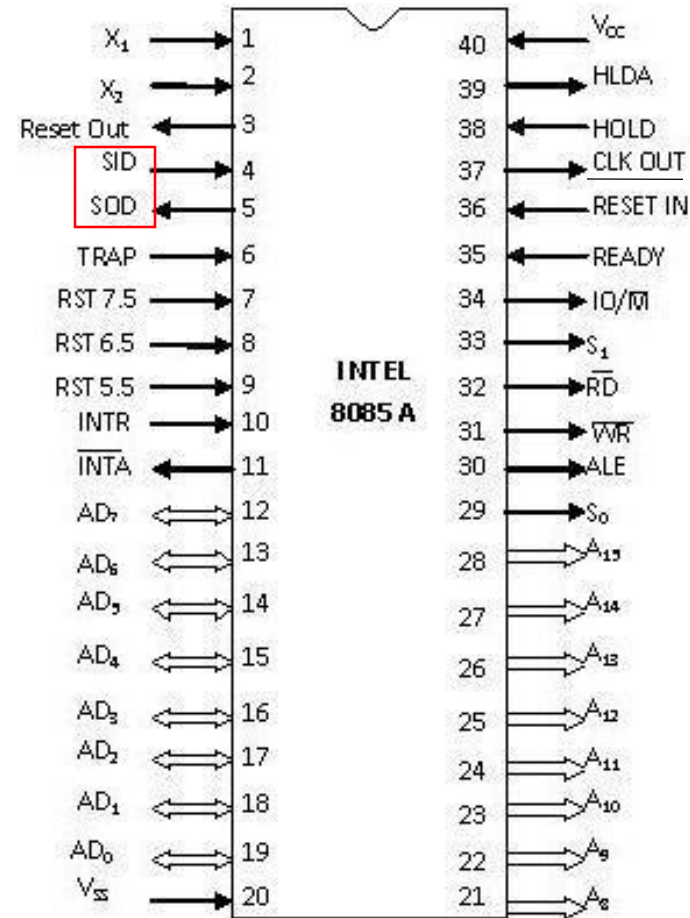

Interrupt Pins

- **Interrupt:**
 - It means *interrupting* the normal execution of the microprocessor.
 - When microprocessor receives interrupt signal, it discontinues whatever it was executing.
 - It starts executing new program indicated by the interrupt signal.
 - Interrupt signals are generated by external peripheral devices.
 - After execution of the new program, microprocessor goes back to the previous program.

Sequence of Steps Whenever There is an Interrupt

- Microprocessor completes execution of current instruction of the program.
- PC contents are stored in stack.
- PC is loaded with address of the new program.
- After executing the new program, the microprocessor returns back to the previous program.
- It goes to the previous program by reading the top value of stack.

Five Hardware Interrupts in 8085

- TRAP
- RST 7.5
- RST 6.5
- RST 5.5
- INTR

Classification of Interrupts

- Maskable and Non-Maskable
- Vectored and Non-Vectored

Maskable Interrupts

- Maskable interrupts are those interrupts which can be *enabled* or *disabled*.
- Enabling and Disabling is done by software instructions.

Maskable Interrupts

- List of Maskable Interrupts:
 - RST 7.5
 - RST 6.5
 - RST 5.5
 - INTR

Non-Maskable Interrupts

- The interrupts which are always in *enabled* mode are called non-maskable interrupts.
- These interrupts can never be disabled by any software instruction.
- TRAP is a non-maskable interrupt.

Vectored Interrupts

- The interrupts which have fixed memory location for transfer of control from normal execution.
- Each vectored interrupt points to the particular location in memory.

Vectored Interrupts

- List of vectored interrupts:
 - RST 7.5
 - RST 6.5
 - RST 5.5
 - TRAP

Vectored Interrupts

- The addresses to which program control goes:

Name	Vectored Address
RST 7.5	003C H (7.5 x 0008 H)
RST 6.5	0034 H (6.5 x 0008 H)
RST 5.5	002C H (5.5 x 0008 H)
TRAP	0024 H (4.5 x 0008 H)

ue

Non-Vectored Interrupts

- The interrupts which don't have fixed memory location for transfer of control from normal execution.
- The address of the memory location is sent along with the interrupt.
- INTR is a non-vectored interrupt.

TRAP

Pin 6 (Input)

- It is a non-maskable interrupt.
- It has the highest priority.
- It cannot be disabled.
- It is both edge and level triggered.
- It means TRAP signal must go from low to high.
- And must remain high for a certain period of time.
- TRAP is usually used for power failure and emergency shutoff.

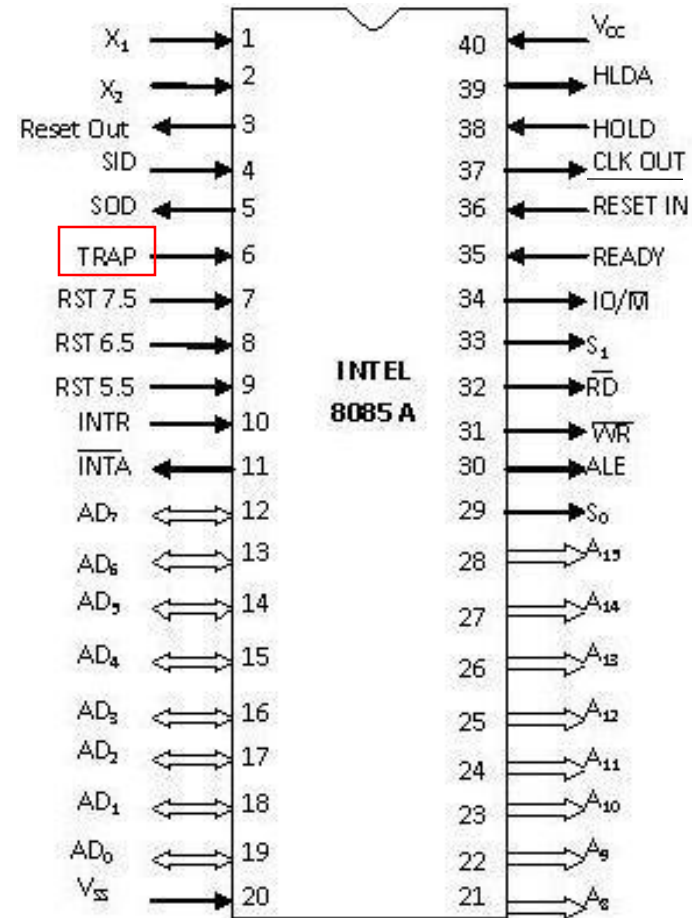

RST 7.5

Pin 7 (Input)

- It is a maskable interrupt.
- It has the second highest priority.
- It is positive edge triggered only.
- The internal flip-flop is triggered by the rising edge.
- The flip-flop remains high until it is cleared by RESET IN.

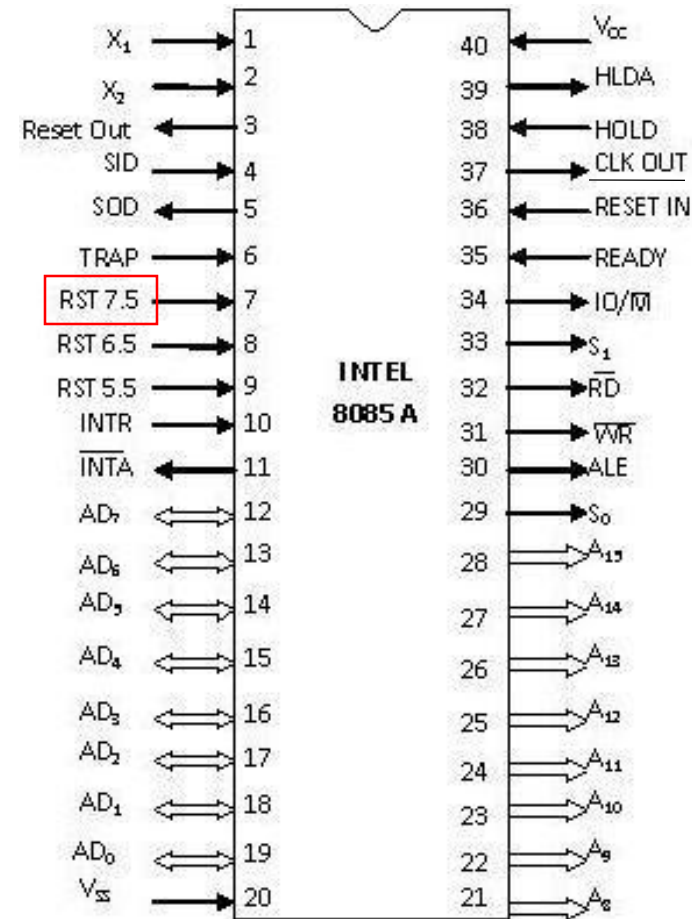

RST 6.5

Pin 8 (Input)

- It is a maskable interrupt.
- It has the third highest priority.
- It is level triggered only.
- The pin has to be held high for a specific period of time.
- RST 6.5 can be enabled by EI instruction.
- It can be disabled by DI instruction.

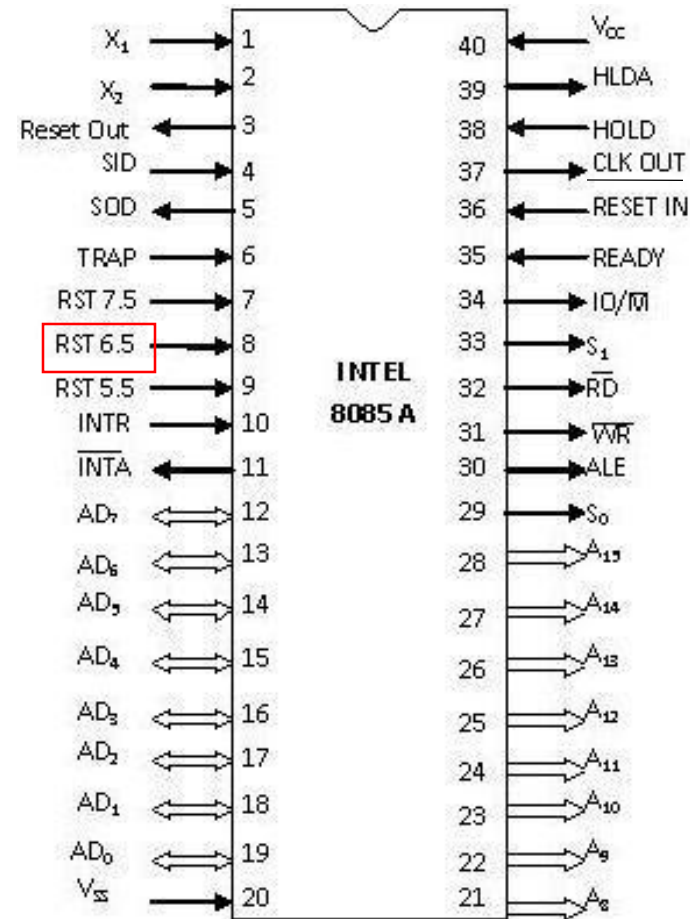

RST 5.5

Pin 9 (Input)

- It is a maskable interrupt.
- It has the fourth highest priority.
- It is also level triggered.
- The pin has to be held high for a specific period of time.
- This interrupt is very similar to RST 6.5.

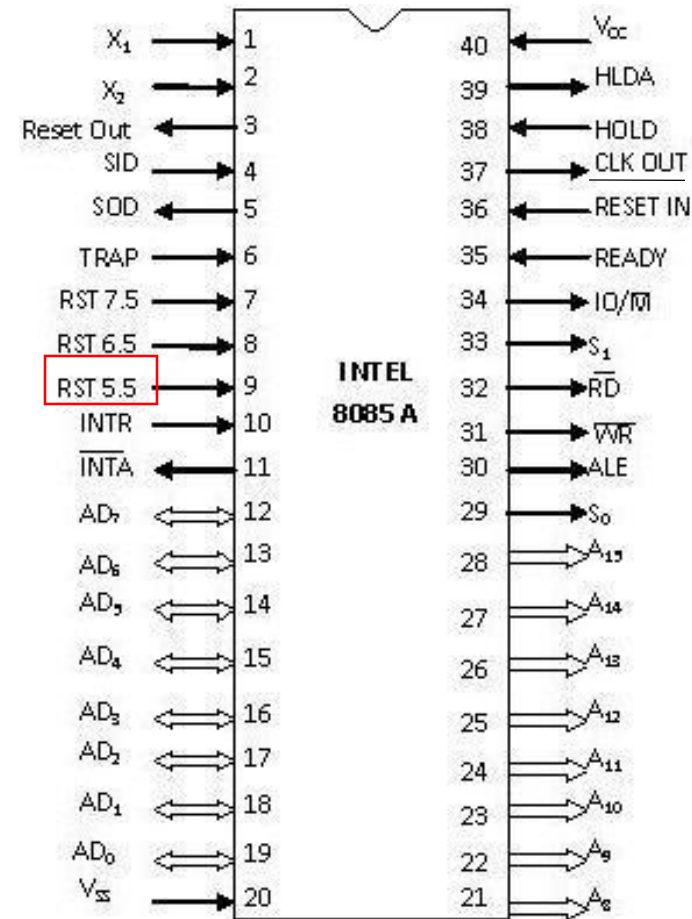

INTR

Pin 10 (Input)

- It is a maskable interrupt.
- It has the lowest priority.
- It is also level triggered.
- It is a general purpose interrupt.
- By general purpose we mean that it can be used to vector microprocessor to any specific subroutine having any address.

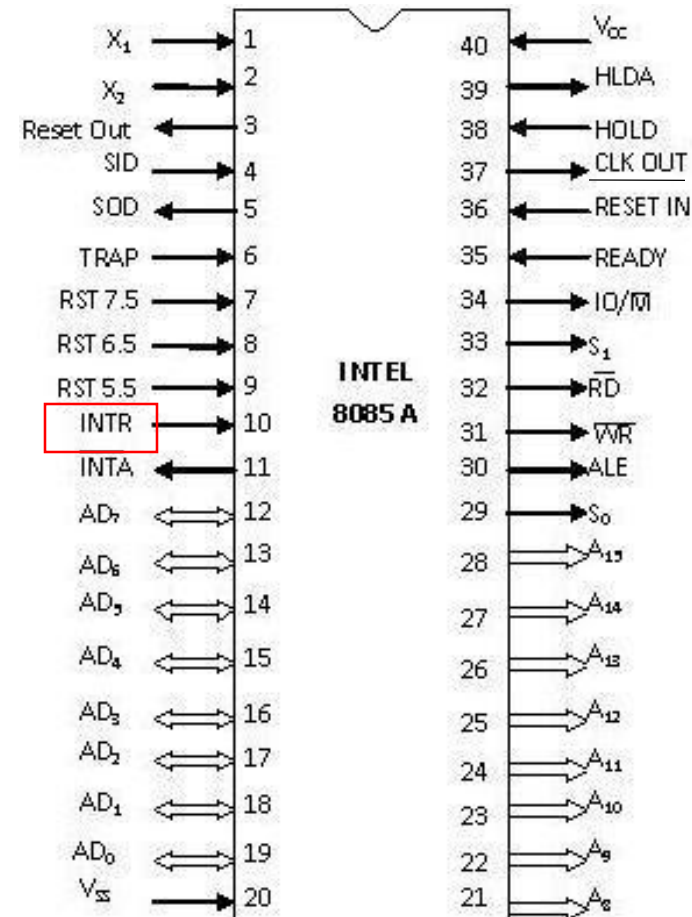

INTA

Pin 11 (Output)

- It stands for interrupt acknowledge.
- It is an out going signal.
- It is an active low signal.
- Low output on this pin indicates that microprocessor has acknowledged the INTR request.

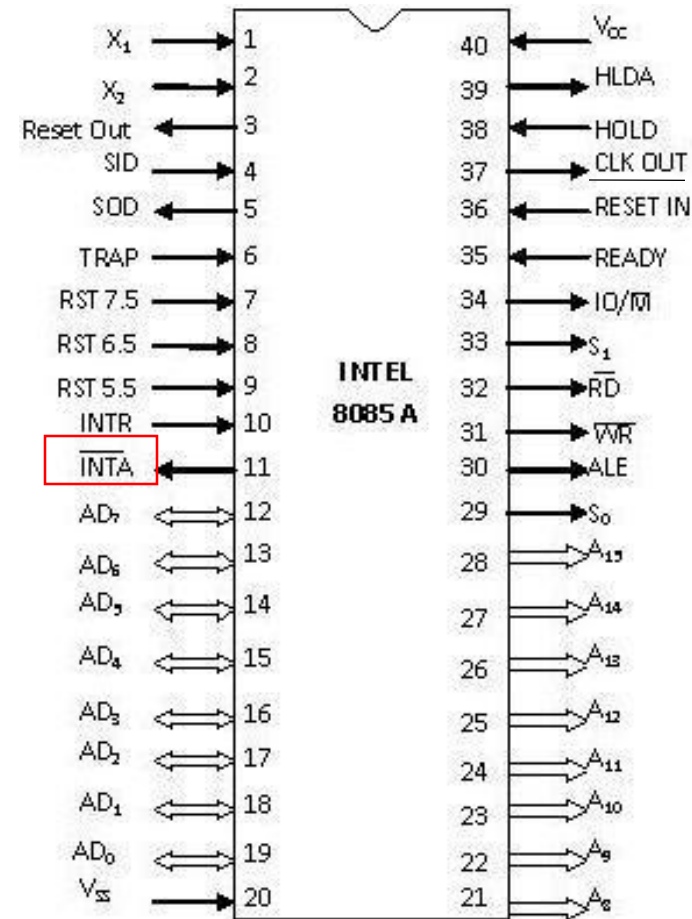

Address and Data Pins

- **Address Bus:**

- The address bus is used to send address to memory.
- It selects one of the many locations in memory.
- Its size is 16-bit.

Address and Data Pins

- **Data Bus:**
 - It is used to transfer data between microprocessor and memory.
 - Data bus is of 8-bit.

AD₀ – AD₇

Pin 19-12 (Bidirectional)

- These pins serve the dual purpose of transmitting lower order address and data byte.
- During 1st clock cycle, these pins act as lower half of address.
- In remaining clock cycles, these pins act as data bus.
- The separation of lower order address and data is done by address latch.

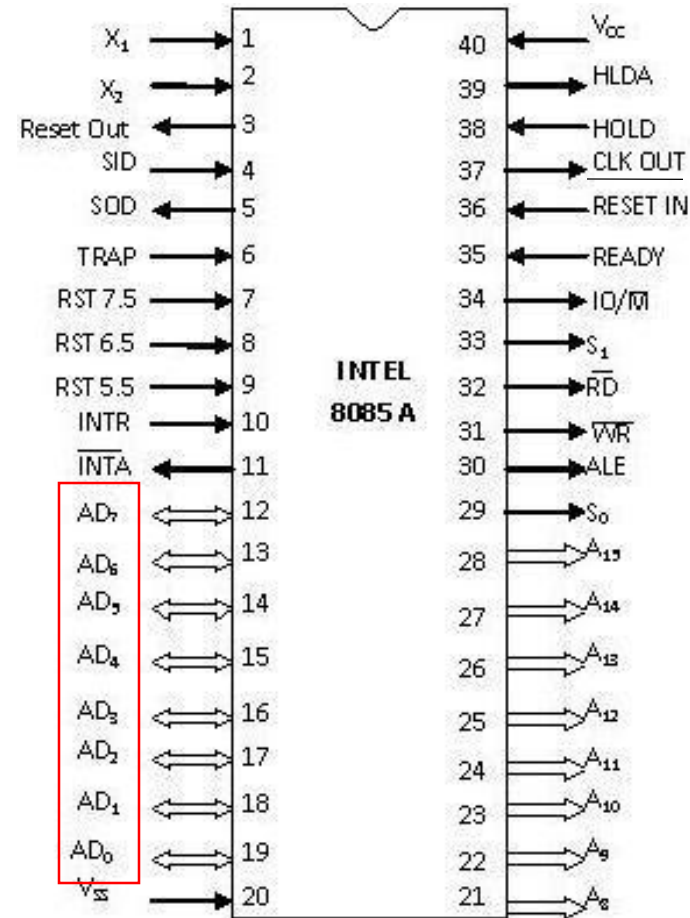

$A_8 - A_{15}$ Pin 21-28 (Unidirectional)

- These pins carry the higher order of address bus.
- The address is sent from microprocessor to memory.
- These 8 pins are switched to high impedance state during HOLD and RESET mode.

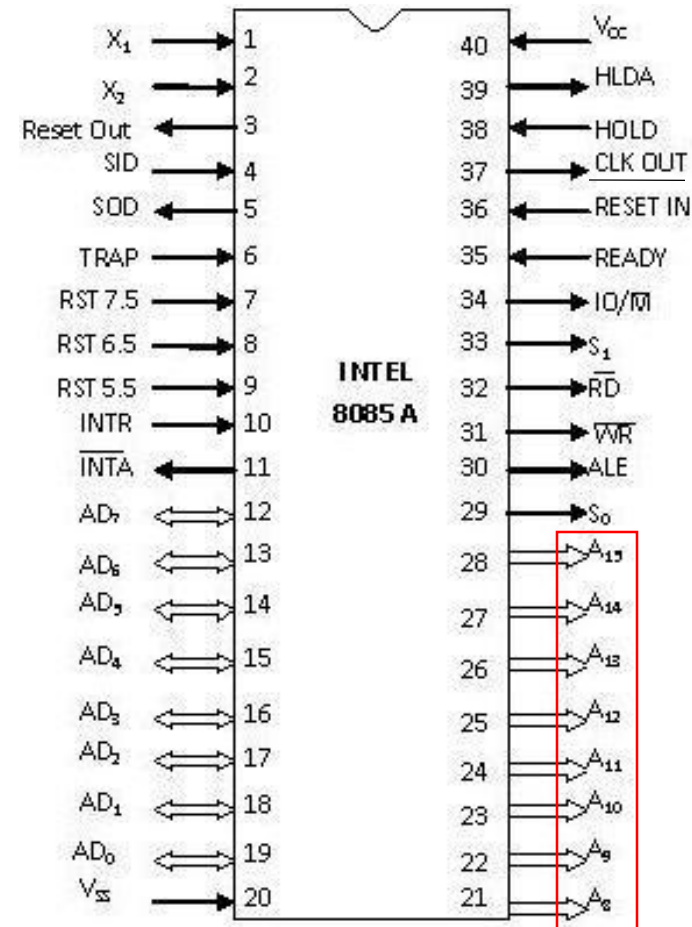

ALE

Pin 30 (Output)

- It is used to enable Address Latch.
- It indicates whether bus functions as address bus or data bus.
- If ALE = 1 then
 - Bus functions as address bus.
- If ALE = 0 then
 - Bus functions as data bus.

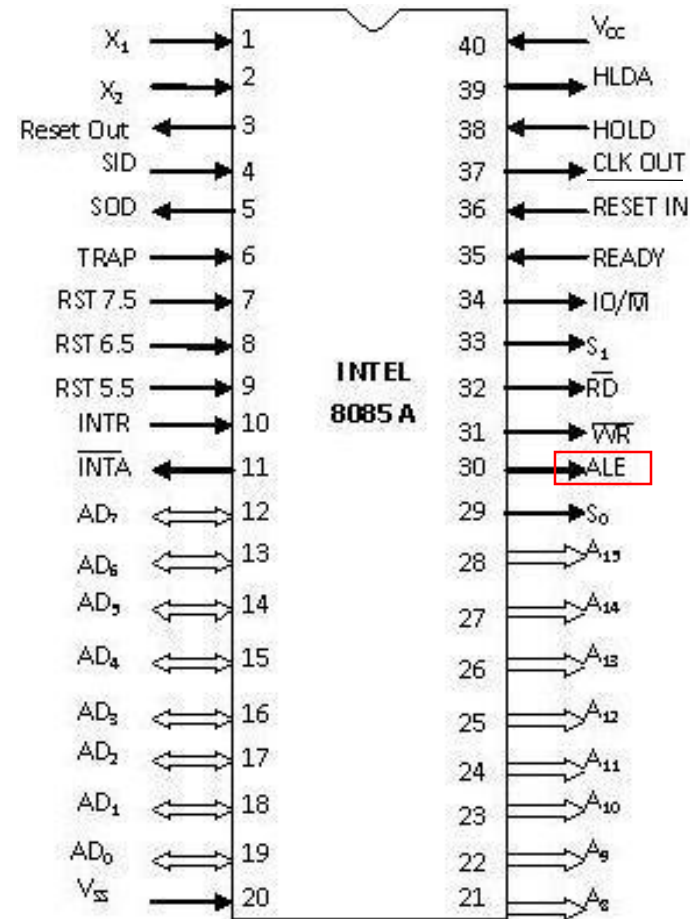

S₀ and S₁

Pin 29 (Output) and Pin 33 (Output)

- S₀ and S₁ are called Status Pins.
- They tell the current operation which is in progress in 8085.

S ₀	S ₁	Operation
0	0	Halt
0	1	Write
1	0	Read
1	1	Opcode Fetch

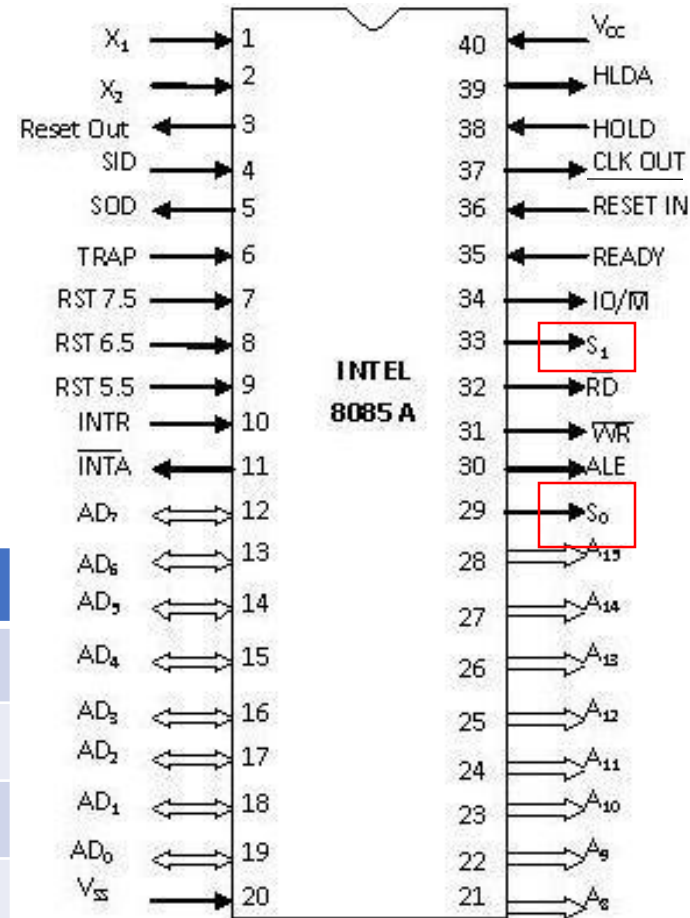

IO/M

Pin 34 (Output)

- This pin tells whether I/O or memory operation is being performed.
- If $IO/M = 1$ then
 - I/O operation is being performed.
- If $IO/M = 0$ then
 - Memory operation is being performed.

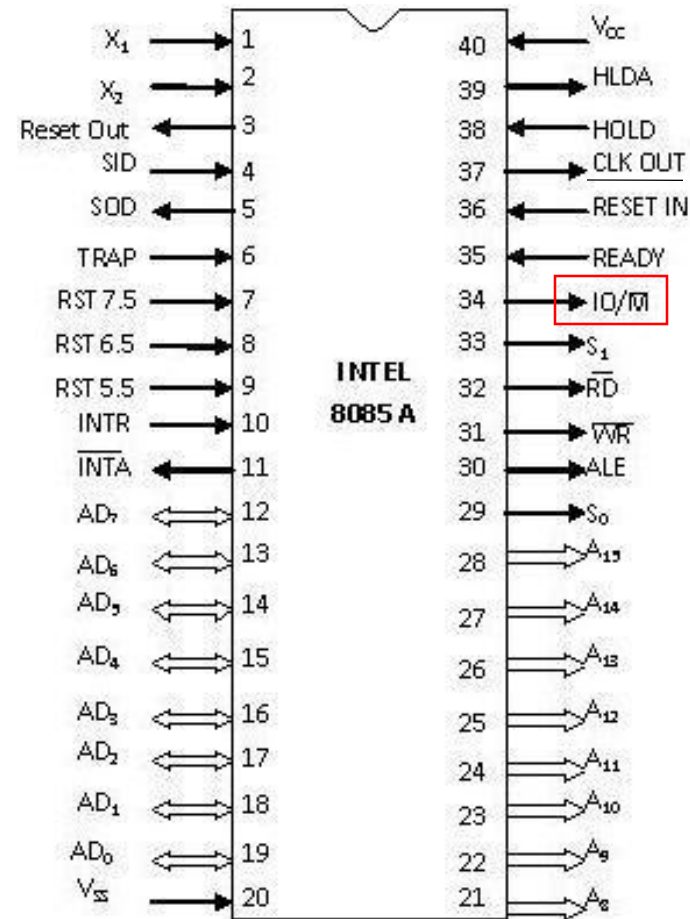

IO/M

Pin 34 (Output)

- The operation being performed is indicated by S_0 and S_1 .
- If $S_0 = 0$ and $S_1 = 1$ then
 - It indicates WRITE operation.
- If $IO/M = 0$ then
 - It indicates \overline{MEM} Memory operation.
- Combining these two we get **Memory Write** Operation.

Table Showing IO/ \overline{M} , S_0 , S_1 and Corresponding Operations

Operations	IO/ \overline{M}	S_0	S_1
Opcode Fetch	0	1	1
Memory Read	0	1	0
Memory Write	0	0	1
I/O Read	1	1	0
I/O Write	1	0	1
Interrupt Ack.	1	1	1
Halt	High Impedance	0	0

RD

Pin 32 (Output)

- RD stands for Read.
- It is an active low signal.
- It is a control signal used for Read operation either from memory or from Input device.
- A low signal indicates that data on the data bus must be placed either from selected memory location or from input device.

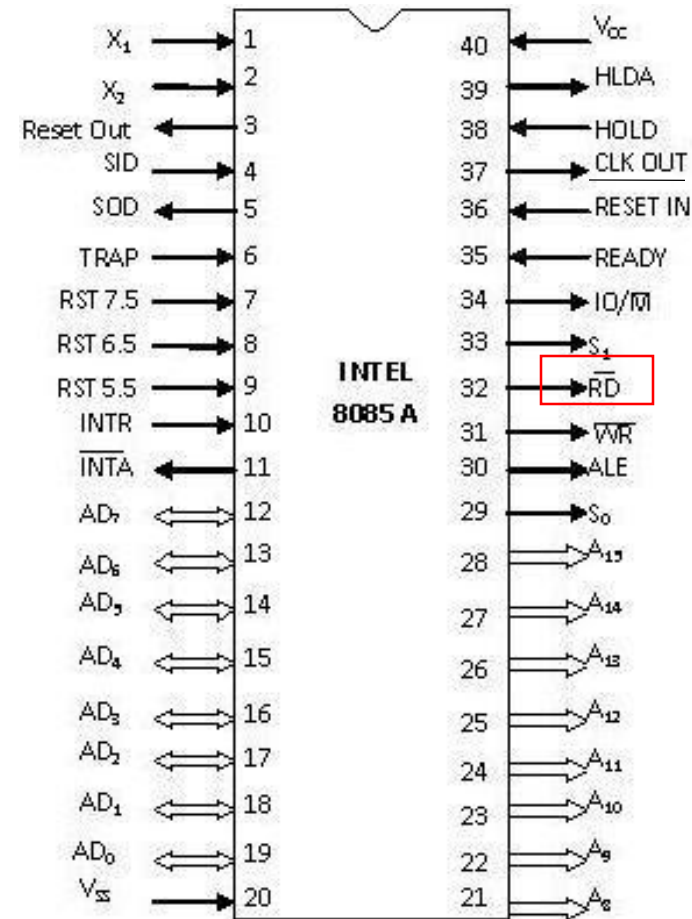

WR

Pin 31 (Output)

- WR stands for Write.
- It is also active low signal.
- It is a control signal used for Write operation either into memory or into output device.
- A low signal indicates that data on the data bus must be written into selected memory location or into output device.

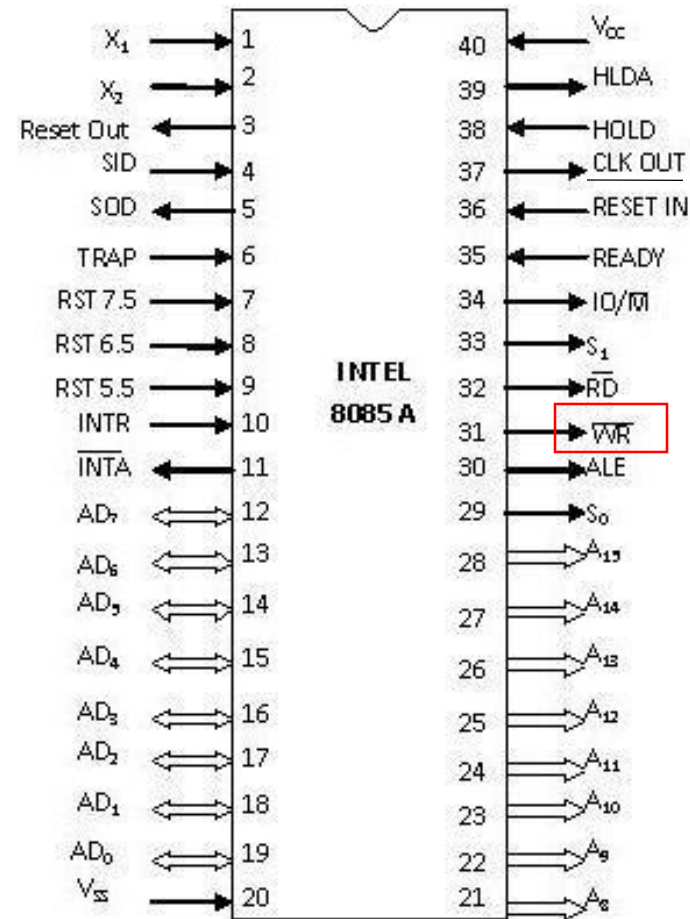

READY

Pin 35 (Input)

- This pin is used to synchronize slower peripheral devices with fast microprocessor.
- A low value causes the microprocessor to enter into **wait state**.
- The microprocessor remains in wait state until the input at this pin goes high.

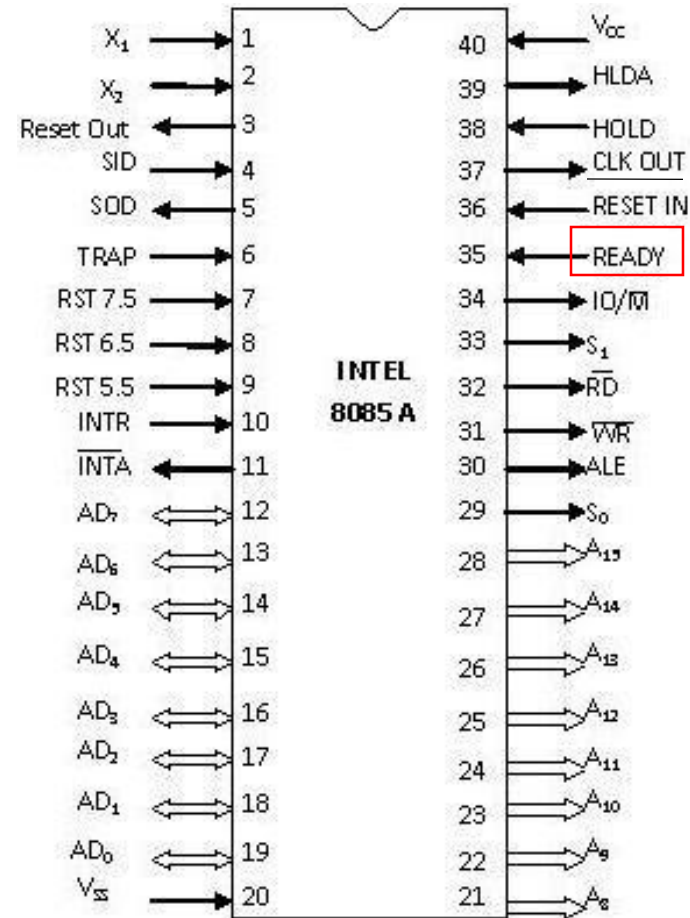

HOLD

Pin 38 (Input)

- HOLD pin is used to request the microprocessor for DMA transfer.
- A high signal on this pin is a request to microprocessor to relinquish the hold on buses.
- This request is sent by DMA controller.
- Intel 8257 and Intel 8237 are two DMA controllers.

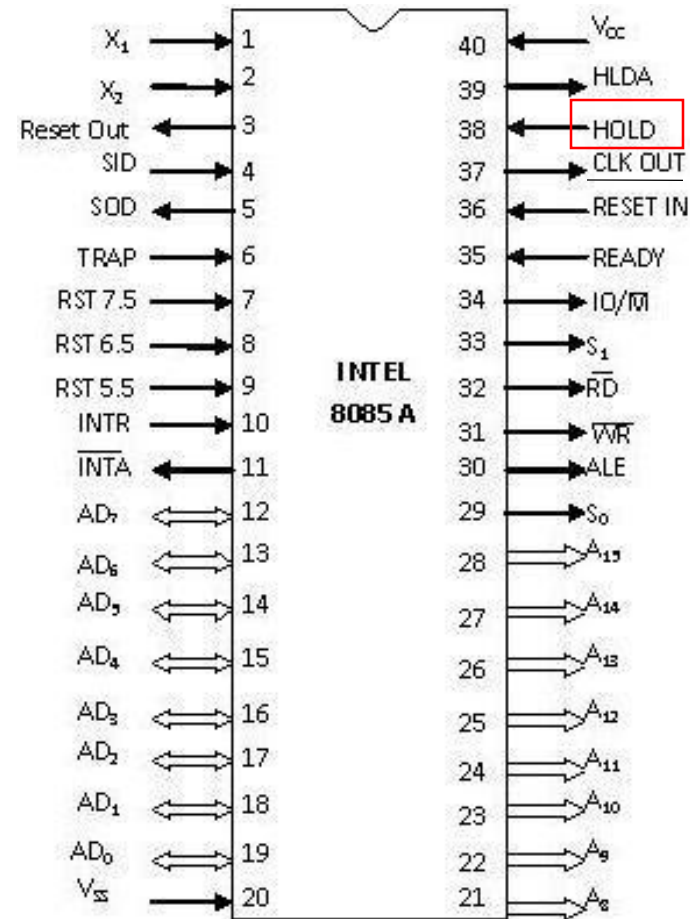

HLDA

Pin 39 (Output)

- HLDA stands for Hold Acknowledge.
- The microprocessor uses this pin to acknowledge the receipt of HOLD signal.
- When HLDA signal goes high, address bus, data bus, RD, WR, IO/M pins are **tri-stated**.
- This means they are cut-off from external environment.

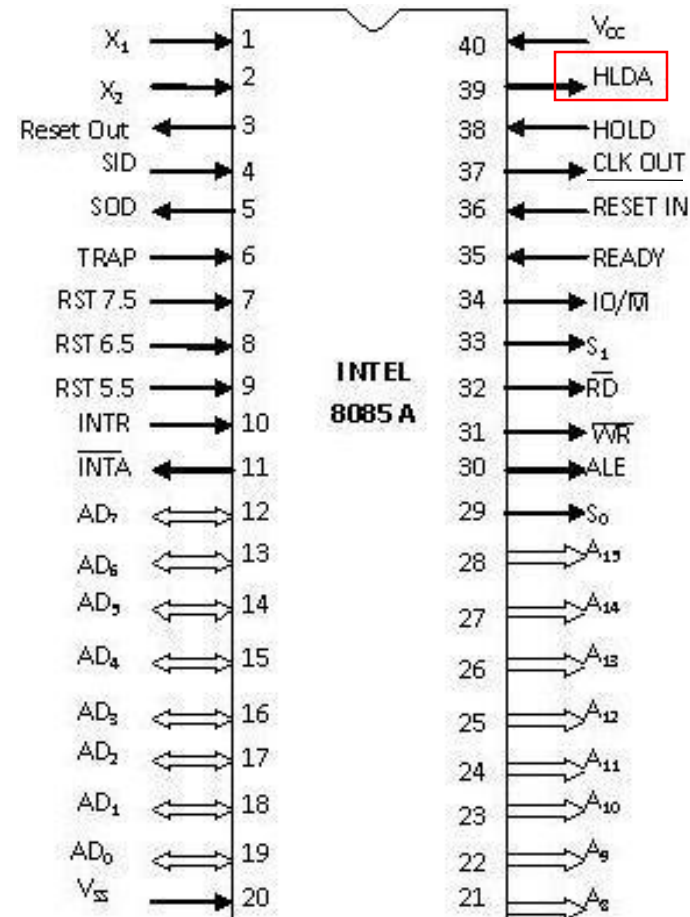

HLDA

Pin 39 (Output)

- The control of these buses goes to DMA Controller.
- Control remains at DMA Controller until HOLD is held high.
- When HOLD goes low, HLDA also goes low and the microprocessor takes control of the buses.

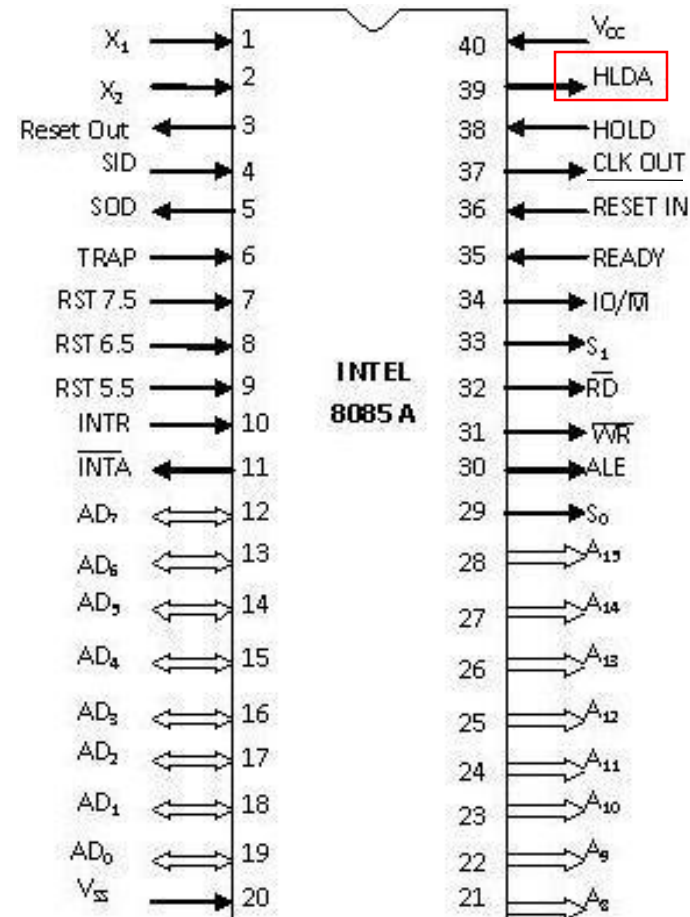

V_{SS} and V_{CC}

Pin 20 (Input) and Pin 40 (Input)

- +5V power supply is connected to V_{CC} .
- Ground signal is connected to V_{SS} .

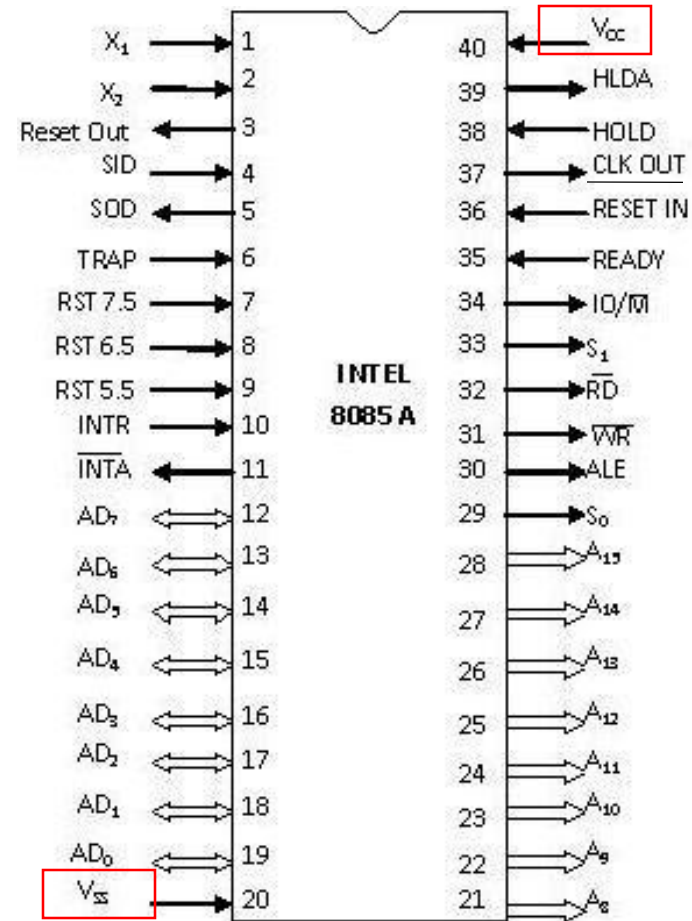

THE END